



srl

POLYLIFTE

TECHNICAL PARTICULARS

T26

H 180

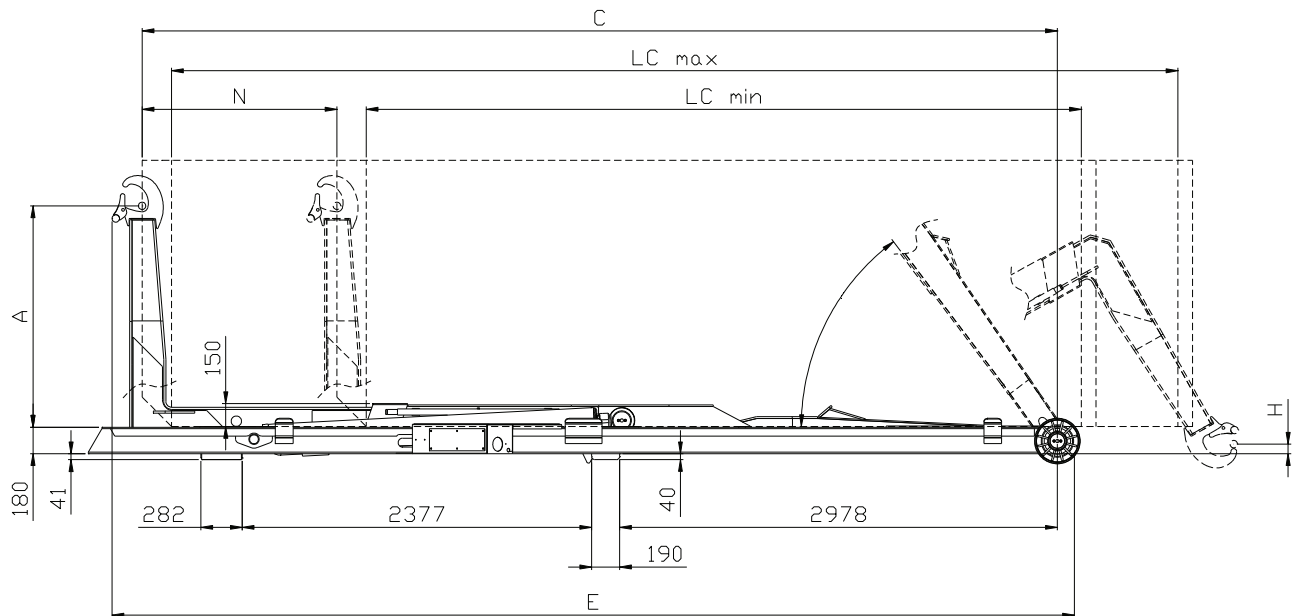

LIFTING CAPACITY	26 T				
HOOKLIFT WEIGHT	2950			2990	
TOTAL LENGTH (E)	6140	6340	6540	6740	6940
HOOK-ROLLER CENTRE DISTANCE (C)	5800	6000	6200	6400	6600
CONTAINER WORKING LENGTH (LC min)	5100			5300	
CONTAINER WORKING LENGTH (LC max)	6400	6600	6800	7000	7200
HOOK HEIGHT (A)	1480				
CONTAINER PICKING UP HEIGHT (H)	130			185	
HOOKARM STROKE (N)	925	1125	1325	1325	1525
WIDTH OF THE FRAME	1060				
MAX TILTING ANGLE (α)	53°				
LOADING ANGLE (max/min)*	38°/28°			39°/27°	
OPERATING PRESSURE (bar)	340			350	
PUMP DELIVERY / 1000 r (Lt / min)	60				
OIL TANK (Lt)	150				
CENTRE OF GRAVITY (Dimension referred to sliding roller centre)	3280	3300	3350	3470	3510

* truck height 900 mm.